

# MT-500 series



## MT-510T, MT-508T Installation Instruction

### 1.0 Installation and Startup

## Guide

### Install Environment

#### Where Used

The MT-500 Series is designed for use in a factory environment. It is designed to operate from 32 to 113 °F (0 to 45 °C) temperatures, as found in most industrial environments. It may not be suitable for use in certain outdoor applications. Please consult the factory for advised usage in outdoor applications.

#### NEMA Rating

The MT-500 Series front bezel is NEMA 4 rated. When installed properly in a NEMA 4 panel, the NEMA 4 rating of the panel will not be compromised. This means that fluids will not enter the panel during wash downs.

#### Electrical Environment

The MT-500 Series has been tested to conform to European CE requirements. This means that the circuitry is designed to resist the effects of electrical noise. This does not guarantee noise immunity in severe cases. Proper wire routing and grounding will insure proper operation.

#### Mechanical Environment

Avoid installing units in environments where severe mechanical vibration or shocks are present.



## 2.0 Installation Instructions

### 2.1 Mounting Instructions

#### 2.1.1 Location Considerations

Care should be taken when locating equipment behind the unit to ensure that AC power wiring, PLC output modules, contactors, starters and relays, and any other source of electrical interference are located away from the back of the unit.

Particular note should be taken to the position of variable speed drives and switching power supplies. Their input and load cables should be screened to a central star earth point.

## 2.1.2 Making a NEMA-4 Mounting

### Panel Details

The unit can be mounted into panels with a depth of 4” (105mm). It is recommended that the unit be mounted on the front panel of a steel enclosure, through an appropriate opening\*. Allow a clearance of 1”(25mm) around the sides of the unit for mounting hardware. Allow clearance for cable connections to the back of the unit. Unit depth may vary according to cable type used. Typically, plan a depth to accommodate at least 4” (105mm) behind the panel.

### NEMA-4 Mounting

Put the unit through the panel cut out. Slide the clamps into the 6 holes provided around the case. Tighten the clamping screws in an even pattern until the unit is secured in the panel.

### Caution!

Do not over tighten mounting clamps!

### Note:

#### Specifications

Note: To seal to NEMA-4 specifications, all supplied mounting clamps must be used and panel cannot flex more than 0.010”.

## 2.1.3 Environmental Considerations



- The MT-500 are to be used indoors as built in displays. Make sure that the displays are installed correctly and that the operating limits are followed (See Specifications).
- Do not operate the unit in areas subject to explosion hazards due to flammable gases, vapors or dusts.
- The unit should not be installed where fast temperature variations and/or high humidity are present. This will cause condensation of water in the device.
- Do not install these terminals in environments where have inflammable gases.

## 2.2 Power Connections

Make sure that all local and national electrical standards are met when the installing the unit. Contact your local authorities to determine which codes apply.

### 2.2.1 Power Requirements



#### Power

The MT-500 can be powered by DC power only. The specified voltage range is  $24 \pm 5\%$  Volts DC. This insures compatibility with most controller DC systems.

The power conditioning circuitry inside the unit is accomplished by a switching power supply. The peak starting current can be as high as 700mA.



#### Fusing Requirements

If the display does not come on within 2 seconds of power up, remove power. An internal fuse will prevent damage if the polarity of the DC power is incorrect. Check wiring to insure proper connections and try to power up again.



#### Caution High Voltage

An Internal fuse will prevent damage for over voltage condition however it isn't guaranteed.

DC voltage sources should provide proper isolation from main AC power and similar hazards.



#### Caution Emergency Stop

A Hard-wired EMERGENCY STOP should be fitted in any system using an MT-500 to comply with ICS Safety Recommendations.



**Caution  
Supply Voltage  
Condition**

**Do not power the MT-500 and inductive DC loads**, or input circuitry to the controller, with the same power supply. Note: The 24 VDC output from some controllers may not have enough current to power the MT-500.



**Caution  
Wire Routing**

Wire lengths should be minimized (Maximum 1600' (500 m) shielded, 1000' (300 m) unshielded).

Wires should be run in pairs with a neutral or common paired with a hot or signal line.

If wiring is to be exposed to lightning or surges, use appropriate surge suppression devices.

Keep AC, high energy, and rapidly switching DC wiring separate from signal wires.

Equip ungrounded DC supplies with a resistor and capacitor in parallel to earth ground. This provides a path for static and high frequency dissipation. Typical values to use are 1M $\Omega$  and 4700pF.

**Connection**

To make a connection, strip about 3/8" of insulation off the end of the wire, turn the connector screw counterclockwise until the gap is wide open, insert the wire all the way in, and turn the screw clockwise until it's tight.

Connect positive DC line to the '+24V' terminal and the DC ground to the '0V' terminal.

**2.2.2 Grounding Requirements**



Chassis ground must be used. DC ground is not directly coupled to Earth ground internally. It is preferable not to ground DC negative return to chassis ground as poor site earths can introduce noise into a system, but if necessary an earth connection should be made, from the power supply return point to the central star earth point. Ground conductors should be as short and as large in size as possible. The conductors must always be large enough to carry the maximum short circuit current of the path being considered. Ground conductors should be connected to a tree from a central star earth ground point. This ensures that no ground conductor carries current from any other branch.

**2.2.3 CE Requirements**

To make an MT-500 comply with EMC directives, and to reduce susceptibility to electrical interference, a separate #14 AWG ground wire should be taken to the chassis ground terminal of the power connector. This ground connection should be run directly to the central star earth connection point (as recommended in most Installation Instructions).

**2.2.4 Safety Guidelines**

This section presents recommended installation practices, and procedures. Since no two applications are identical, these recommendations should be considered as guidelines.

**Hardware  
Considerations**

**WARNING!**



The system designer should be aware that devices in Controller systems could fail and thereby create an unsafe condition. Furthermore, electrical interference in an operator interface, such as an MT-500, can lead to equipment start-up, which could result in property damage and/or physical injury to the equipment operator.

If you, or your company, use any programmable control systems that require an operator or attendant, you should be aware that this potential safety hazard exists and take appropriate precautions. Although the specific design steps depend on your particular application, the following precautions generally apply to installation of solid-state programmable control devices. In addition, these precautions conform to the guidelines for installation of Controllers as recommended in the NEMA ICS 3-304 Control Standards.

**Programming Considerations**

To conform with ICS Safety Recommendations, checks should be placed in the controller to ensure that all writable registers that control critical parts of plant or machinery have limit checks built into the program, with an out-of-limit safe shut down procedure to ensure safety of personnel.

**ICS 3-304.81 Safety Recommendations:**

*Consideration should be given to the use of an emergency stop function, which is independent of the programmable controller.*

*Where the operator is exposed to the machinery, such as in loading or unloading a machine tool, or where the machine cycles automatically, consideration should be given to the use of an electromechanical override or other redundant means, independent of the programmable controller, for starting and interrupting the cycle.*

*If provision is required for changing programs while the equipment is in operation, consideration should be given to the use of locks or other means of assuring that only authorized personnel can make such changes.*

*These recommendations are intended as safeguards against the failure of critical components and the effects of such failures or the inadvertent errors that might be introduced if programs are changed while the equipment is in operation. \**

- The ICS 3-304.81 Safety Recommendations are reproduced by permission of the National Electrical Manufacturers Association from NEMA ICS 3-304

## 2.3 Communications Connections

The ports as you look at the back of the case, are the ports for connecting to a printer, PLC or some external device (Controller Connectors).

### 2.3.1 Connection to an External Device

**Cable Requirements**

Different cables are required for various devices.

**Caution**

Restrict cable length to less than 500' (150m) for RS485/422 devices and 50' (15m) for RS232 devices to avoid communications problems. Communications problems cause the display to show "PLC no response..." until communications can be established. The COM light on the front of the MT-500 will turn on with each communication.

Shielded cable must be used for long lengths or cables run in an electrically noisy environment.

Do not run cables next to AC power lines or near sources of electrical noise.

Be sure that the cable ends have been inserted all of the way into mating connectors and are secure

**Pin Designations**

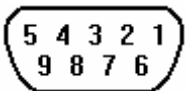

PLC [RS-232]

Pin assignment of the 9 Pin, Female, SUB-D, PLC [RS-232] Port. This port is used for connecting the MT-500 to a controller.

**Note:** This port is not used for programming the MT-500 or for printing functions.

Pin#	Symbol	PLC [RS232]	AUX[RS232] (only E series)
1	Aux_TxD		Transmitted Data
2	TxD	Transmitted Data	
3	RxD	Received Data	
4	Not used		
5	GND	Signal Ground	
6	Aux_RxD		Received Data
7	CTS	Clear to send input	
8	RTS	Ready to send output	
9	+5V		

### 2.3.2 Connection to a Personal Computer

The 9 Pin, Female, SUB-D, PC [RS-232] & PLC [RS-485] Port on the back of the unit is the programming port (PC Connector) and RS485/422 communications port for connecting to a controller.

**Connection**

This port can be attached to a Computer via a special DB9 Female to DB9 Female cable. (P/N: MT5\_PC, optional)

**Port Activation**

This port is activated automatically by the PC during on line simulation, download and upload activities.

The Programmer Port cannot simulate, download or upload to the MT-500 while it is on line with the controller at the same time. The MT-500 must be put into “RDS” mode with the EasyManager applet first.

**Pin Designations**

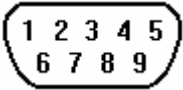

PC [RS-232] & PLC [RS-485]

Pin assignment of the 9 Pin, Male, SUB-D PC [RS-232] & PLC [RS-485] Port. (Only MT5XXXE4 has AUX RS485)

Pin#	Symbol	PLC[RS485] 4 wire	PLC[RS485] 2 wire	Aux[RS485] (only E series)	PC[RS232]
1	Rx-	Rx-	Data-		
2	Rx+	Rx+	Data+		
3	Tx-	Tx-			
4	Tx+	Tx+			
5	GND	Signal Ground			
6	Data-			Data-	
7	TxD				Transmit
8	RxD				Receive
9	Data+			Data+	

**MT-500 to PC  
MT5\_PC Cable  
Configuration**

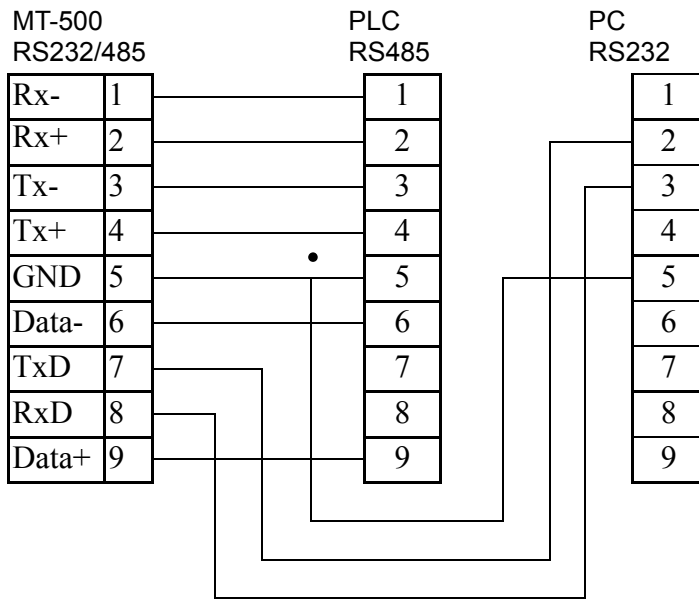
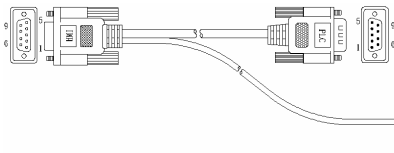

### 2.3.3 Connection to a Printer

The printer port on the back of the unit is a Parallel printer port and is compatible with most printers that accept parallel connectors.

**Print Out**

The MT-510T and MT-508T models have print out capabilities. The printer port transmits data when a printable object is activated. MT-500 support compatible with EPSON ESC/P2 printer. For details, contact your local distributor.

Note: Connect printer the distance can't longer than 5m.

**Pin Designations**

Pin assignment of the 25 Pin, SUB-D, Parallel Printer Port.

13 12 11 10 9 8 7 6 5 4 3 2 1  
25 24 23 22 21 20 19 18 17 16 15 14

PRINTER

Pin#	Symbol	Function	Pin#	Symbol	Function
1	STB	Output	11	BUSY	Input
2	DATA0	Output	15	ERROR	Input
3	DATA1	Output	16	INIT	Output
4	DATA2	Output	17-25	GND	Signal Ground
5	DATA3	Output			
6	DATA4	Output			
7	DATA5	Output			
8	DATA6	Output			
9	DATA7	Output			

### 2.3.4 Dip Switch

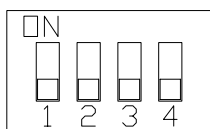

SW1	SW2	Mode
ON	ON	Touch Screen Test mode
OFF	ON	RDS (Remote Debug & Simulation) mode
ON	OFF	Touch Adjust (Touch screen calibration) mode
OFF	OFF	Application (On line operation) mode

- Touch Screen Test mode: In this mode when you touch the screen, the screen will display a “+” sign. So you can test the touch screen was accurate.
- RDS (Remote Debug & Simulation) mode: Used for simulation and download/upload. When E4 series insert a CF card will appear a green button on screen right and bottom side. Press this button to startup the project download procedure.
- Touch Adjust (Touch screen calibration) mode: Used to calibrate the touch screen.
- Application (On line operation) mode: This is the normal operating mode of the EasyView; the EasyView will start from the startup window of the project download.

## 2.4 CE Requirements

### EU directives that apply to the MT-500 Series:

- EMC Directive (89/336/EEC, 92/31/EEC, 93/68/EEC) electromagnetic emissions and immunity
- Machinery Directive (89/392/EEC, 91/368/EEC, 93/44/EEC, 93/68/EEC) machine safety
- MT500 products will be CE-marked to indicate compliance with the EMC Directive.

The MT-500 Series has been designed to operate satisfactorily in electromagnetic noise (immunity) and without emitting high levels of electrical noise into the environment (emission). The units are designed to meet European Community standards when installed per the wiring instructions in this manual.

### Compatibility Standards

The MT-500 has been designed to meet electromagnetic compatibility for industrial environments.

- CISPR (EN 55011) Group 1, Class A Radiated Emissions levels
- EN50081-2 Generic emission standard, industrial environment (Also US FCC Class A)
- EN50082-2 Generic immunity standard, industrial environment

# 3.0 Specifications

	MT510TE	MT510TV	MT508TE	MT508TV
<b>Hardware Specification</b>				
Display	10.4" TFT	10.4" TFT	8" TFT	8" TFT
Brightness	400 cd/m2	400 cd/m2	400 cd/m2	400 cd/m2
Color	256 color	256 color	256 color	256 color
Contrast Ratio	300:1	300:1	250:1	250:1
Resolution (WxH dots)	640 x 480	640 x 480	640 x 480	640x480
Back light	CCFLx2	CCFLx2	CCFLx1	CCFLx1
CCFL life time	50,000 hr. min.	50,000 hr. min.	50,000 hr. min.	50,000 hr. min.
Touch panel	4 wires resistive type			
Touch Accuracy	2mm			
Surface Hardness	4H			
Serial port	HMI-PC (RS-232) HMI-PLC (RS-232/485) HMI-AUX (RS-232/485)	HMI-PC (RS-232) HMI-PLC (RS-232/485)	HMI-PC (RS-232) HMI-PLC (RS-232/485) HMI-AUX (RS-232/485)	HMI-PC (RS-232) HMI-PLC (RS-232/485)
Ethernet port	10Mbps	N/A	10Mbps	N/A
Processor	32bit RISC CPU 200MHz			
Flash Memory	4MB	2MB	4MB	2MB
Recipe memory	128kB			
Compact Flash card slot	Yes	N/A	Yes	N/A
RTC	Yes			
Parallel printer port	Yes			
System Diagnostic	Power failure detection			
<b>General Specification</b>				
Input Power	24±5% VDC			
Maximum Power Consumption	440 mA@24VDC	440 mA@24VDC	440 mA @24VDC	440 mA @ 24VDC
CE	Complies with EN50081-2 and EN50082-2 standards			
FCC	Complies with FCC Class A			
Voltage resistance	500VAC (1 min.)			
Isolation resistance	Exceed 50MΩ at 500VDC			
Vibration endurance	10 to 25 Hz (X,Y,Z direction 2G 30minutes)			
Protection structure	IP65 front panel (O ring seal)			
Operating Temperature	0~45°C			
Operation humidity	10-90% RH (non -condense)			
Enclosure	Plastic			
Dimensions WxHxD	315x238x62mm	315x238x62mm	231x176x55mm	231x176x55mm
Panel cutout dimension	302 x 225 mm	302 x 225 mm	222 x 167 mm	222 x 167 mm
Weight	Approx.2.0 kg	Approx.2.0 kg	Approx.1.2 kg	Approx.1.2 kg
<b>Software</b>				
Screen Editor Software	EasyBuilder 500 V2.7.0 or later			

# 4.0 Dimensions

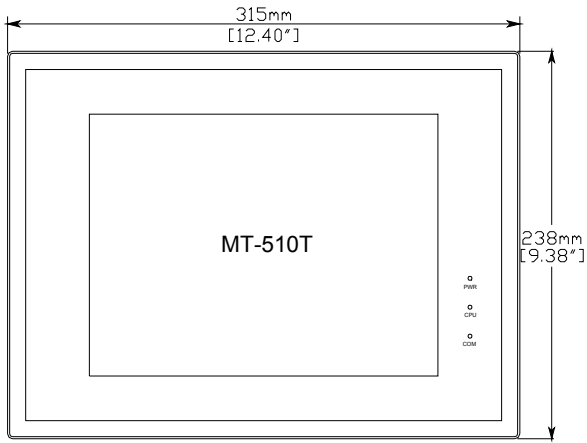

Front View

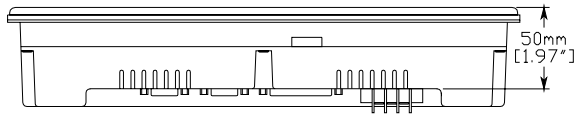
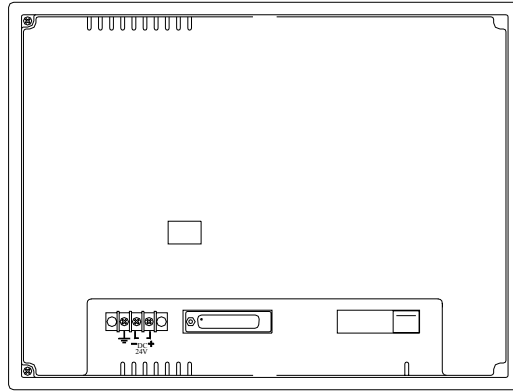

Bottom View

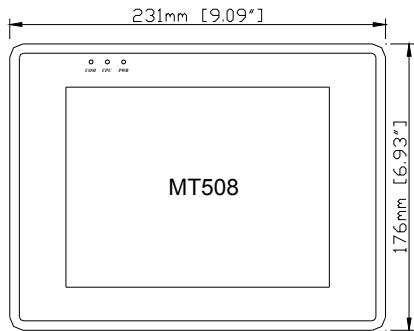

Front View

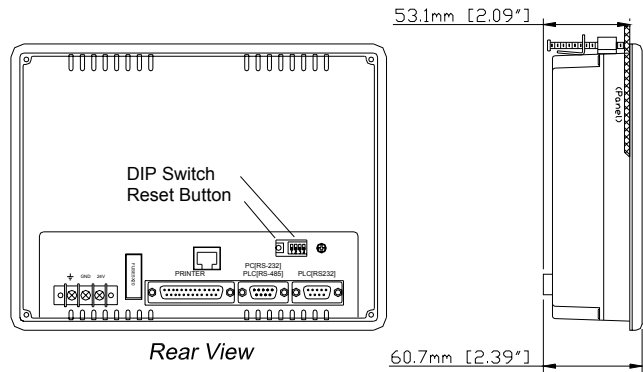

Rear View

Side View

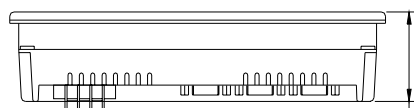

Bottom View

